

# ICC-ES Evaluation Report

**ESR-2224**

Reissued August 1, 2011

This report is subject to renewal in two years.

[www.icc-es.org](http://www.icc-es.org) | (800) 423-6587 | (562) 699-0543

A Subsidiary of the International Code Council®

**DIVISION: 07 00 00—THERMAL AND MOISTURE  
PROTECTION**
**Section: 07 81 33—Mineral-Fiber Fireproofing**
**REPORT HOLDER:**
**UNIFRAX I LLC**  
 2351 WHIRLPOOL STREET  
 NIAGARA FALLS, NEW YORK 14305  
 (716) 278-3800

[www.unifrax.com](http://www.unifrax.com)  
[mkerrison@unifrax.com](mailto:mkerrison@unifrax.com)
**EVALUATION SUBJECT:**
**FYREWAP® ELITE 1.5 AND MAX 2.0 GREASE DUCT  
ENCLOSURE ASSEMBLIES**
**1.0 EVALUATION SCOPE**
**Compliance with the following codes:**

- 2009 *International Building Code*® (2009 IBC)
- 2009 *International Mechanical Code*® (2009 IMC)
- 2009 IAPMO *Uniform Mechanical Code* (2009 IAPMO UMC)
- Other Codes (see Section 8.0)

**Properties evaluated:**

- Durability
- Fire resistance
- Noncombustibility
- Surface-burning characteristics

**2.0 USES**

FyreWrap Elite 1.5 and FyreWrap MAX 2.0 are flexible blankets used to construct zero-clearance, fire-resistance-rated grease duct enclosure assemblies serving Type I kitchen hoods. The systems described in this report comply with IMC Section 506.3.10 and IAPMO UMC Section 507.2.6 and are an alternative to the one- and two-hour fire-resistance-rated enclosure requirements of IBC Section 707.4, and, UBC Section 711 with the exception to IAPMO UMC Section 510.7.1 when installed in accordance with Section 4.0.

**3.0 DESCRIPTION**
**3.1 FyreWrap Blankets:**

**3.1.1 FyreWrap Elite 1.5:** The FyreWrap Elite 1.5 blanket is a calcia, magnesia, silica material. The blanket is

provided unfaced, faced on one side or totally encapsulated in a fiberglass-reinforced aluminum foil scrim. The blanket is nominally 1½ inches (38 mm) thick and is delivered to the jobsite in rolls 25 feet (7.75 m) long and either 2 or 4 feet (610 or 1219 mm) wide. The blankets have a nominal density of 6 pcf (96 kg/m³) and have a flame-spread index of 25 or less and a smoke-developed index of 50 or less when tested in accordance with ASTM E 84.

**3.1.2 FyreWrap MAX 2.0 Blanket:** The FyreWrap MAX 2.0 blanket is a calcia, magnesia, silica material. The blanket is provided either unfaced, faced on one side, or totally encapsulated in a fiberglass-reinforced aluminum foil scrim. The blanket is nominally 2 inches (51 mm) thick and is delivered to the jobsite in rolls 20 feet (6.2 m) long and either 2 or 4 feet (610 or 1219 mm) wide. The blankets have a nominal density of 8 pcf (128.1 kg/m³) and have a flame-spread rating of 25 or less and a smoke-developed rating of 50 or less when tested in accordance with ASTM E 84 (UBC Standard 8-1).

**3.2 Duct System:**

Grease ducts serving Type 1 hoods must be constructed of minimum 0.055-inch-thick (1.40 mm) (No. 16 gage) carbon steel or stainless steel at least 0.044 inch thick (1.10 mm) (No. 18 gage). Joints and seams of grease ducts must comply with IMC Section 506.3.2, or IAPMO UMC Section 510.5.2, as applicable. Duct supports must comply with IMC Section 506.3.3, or IAPMO UMC Section 510.1.7, as applicable, and Section 4.2.3 of this report. Maximum duct size is 49 inches by 49 inches (1244 mm by 1244 mm).

**3.3 Duct Wrap Tape:**

Pressure-sensitive aluminum foil tape having a nominal width of 2 or 4 inches (51 or 102 mm) is used to seal all cut blanket edges. Fiberglass-reinforced filament tape having a nominal width of 1 inch (25.4 mm) is used to temporarily hold the interior and exterior layers of the insulation blanket in position.

**3.4 Banding Material:**

Banding material must be minimum ½-inch-wide (12.7 mm), 0.015-inch-thick (0.38 mm), Type 304 stainless steel strap, or minimum ½-inch-wide (12.7 mm), 0.020-inch-thick (0.51 mm) carbon steel strap.

**3.5 Penetration Seals:**

**3.5.1 Mineral Wool:** Mineral wool blanket used to pack the annular space of penetrations surrounding the duct must have a minimum nominal density of 4 pcf (64 kg/m³).

**3.5.2 GE Silicone Pensil 300:** GE Silicone Pensil 300, used to seal the penetration, is a one-compound silicone elastomeric that cures upon exposure to atmospheric humidity. The sealant is supplied in tubes and pails and has a shelf life of twelve months when stored at temperatures between 40°F and 90°F (4.4°C and 32.2°C).

**3.5.3 STI SpecSeal SSS:** STI SpecSeal SSS Sealant is a one-component, latex-based, high-solids, intumescent firestop compound, that is for use on horizontal and vertical assemblies. Installation temperatures must be between 35°F and 100°F (1.7°C to 37.8°C) and the sealant must be allowed to dry 24 hours before exposure to moisture. It is supplied in tubes and pails.

**3.5.4 Tremco Fyre-Sil:** Tremco Fyre-Sil is a single-component, neutral cure, silicone elastomeric firestop sealant. It has an application temperature range of 40°F to 110°F (5°C to 43°C) and a cure time of seven to fourteen days. The material is supplied in tubes, pails and sausages.

**3.5.5 3M FireBarrier 1000NS:** 3M FireBarrier 1000NS is a ready-to-use, one-component, silicone elastomer firestop sealant, which cures upon exposure to atmospheric humidity to form a flexible seal. The sealant has a shelf life of 12 months from date of packaging when stored in a clean, dry area at temperatures between 40°F and 90°F (4°C and 32°C).

**3.5.6 Hilti FS-ONE:** Hilti FS-ONE is a red-colored, water-based, acrylic intumescent firestop sealant with an application temperature of 41°F to 104°F (5°C to 40°C). The sealant must be stored in original packaging in a location protected from moisture at temperatures between 40°F and 86°F (5°C and 30°C).

### 3.6 Prefabricated Access Doors:

Ductmate Industries, Inc., Ultimate Door and F2-HT doors may be used in lieu of field-fabricated access doors when installed as described in Section 4.2.2.3. The doors and their components are provided as an assembly, are sized for the clean-out opening and are provided with threaded rods and wing nuts for securing the insulation blanket. The door systems include an appropriately sized outer insulation plate and must use the Ductmate-supplied 2300°F gasket.

## 4.0 INSTALLATION

### 4.1 General:

The FyreWrap materials are installed with zero clearance from ducts complying with Section 3.2 of this report, and may be installed with zero clearance from the insulating material to combustible construction. Grease ducts protected with FyreWrap Elite 1.5 or MAX 2.0 may penetrate nonfire-resistance-rated wall, floor-ceiling and roof-ceiling assemblies, provided the duct is protected from the point of penetration in accordance with this report. The system may also penetrate fire-resistance-rated assemblies when the through-penetration is protected in accordance with Section 4.3 of this report. The system complies with the requirements of IMC Section 602.2.1, and IAPMO UMC Section 602.2 for installation in plenums.

### 4.2 Two-hour Fire-resistance-rated Enclosure Assembly:

**4.2.1 Enclosure Assembly:** Two layers of FyreWrap Elite 1.5 or MAX 2.0 blanket material are installed around the grease duct. Each layer is cut to a length sufficient to wrap completely around the perimeter of the grease duct and provide a minimum 3-inch (76 mm) overlap. Adjacent blankets on the first layer are either butted or overlapped

3 inches (76 mm). All overlaps on the second layer are required to be a minimum of 3 inches (76 mm). Aluminum foil tape is used to seal cut edges of the blanket. All joints between layers must be staggered a minimum of 3 inches (76 mm). Each layer of blanket material is temporarily held in place with nominally 1-inch-wide (25.4 mm) filament tape, placed circumferentially 1<sup>1</sup>/<sub>2</sub> inches (38 mm) from the edges of each blanket and spaced 10<sup>1</sup>/<sub>2</sub> inches (267 mm) on center.

Banding is used to hold the outer layer of the blanket enclosure system in place. The bands are placed circumferentially 1<sup>1</sup>/<sub>2</sub> inches (38 mm) from the edges of the blanket and are spaced 10<sup>1</sup>/<sub>2</sub> inches (267 mm) on center. The tension of the banding material must be sufficient to firmly hold the blanket materials in place, but must not be so great as to cause any cutting or damage to the blanket material. Banding is not required to hold the first layer of blanket in place. One-inch-wide (25.4 mm) filament tape may be used to aid installation of the first layer of wrap. See Figure 1 for details.

For duct width dimensions greater than 24 inches (610 mm) through 49 inches (1245 mm), No. 12 gage steel insulation pins, long enough to extend through the two layers of blanket insulation, are located in columns spaced 12 inches (305 mm) apart, between 2 and 12 inches (51 mm and 305 mm) from each duct edge and 10<sup>1</sup>/<sub>2</sub> inches (267 mm) on center along the bottom of horizontal duct runs and along the outside of vertical duct runs, to prevent blanket sag. The insulation pins may be prewelded or cup-head style. The blankets are locked into place over the pins with 1<sup>1</sup>/<sub>2</sub>-inch (38 mm) round or 2-inch-by-2-inch (51 mm by 51 mm) square galvanized steel speed clips. Methods of installing the two-layer system include overlap on all layers method, butt-joint/overlap method or butt-joint/collar method as illustrated in Figure 1. When two blanket layers are encapsulated in one bag, the butt-joint method must be used.

### 4.2.2 Grease Duct Access Doors:

**4.2.2.1 General:** Installation of grease duct access doors must comply with IMC Section 506.3.8, or IAPMO UMC Section 510.3, as applicable. Grease duct access doors must be protected with three layers of FyreWrap Elite 1.5 or MAX 2.0 blanket material.

**4.2.2.2 Field-fabricated Access Doors:** Each access door assembly has four threaded rods, one welded to each corner of the door opening. Each threaded rod measures 1/4 inch (6.4 mm) in diameter and a nominal 6 inches (152.4 mm) in length. Optionally, 4-inch-long (102 mm) hollow steel tubes may be fitted over the threaded rods to act as protective sleeves for the blanket material when the door is fastened. A 0.5-inch-thick (12.7 mm) ceramic fiber gasket is installed between the duct and the door cover. Four steel insulation pins, with a No. 12 gage diameter and a nominal length of 7 inches (178 mm), are welded to the steel door panel, for blanket installation. Two layers of the blanket material are installed over the welded insulation pins, with the second layer having a perimeter 1 inch (25.4 mm) wider than the first. The third layer of blanket material is cut in a similar manner and installed over the second layer. Each subsequent layer must have a minimum overlap of 1 inch (25.4 mm) around the perimeter of the door and any previous blanket layers. The blanket layers are held in place with 1<sup>1</sup>/<sub>2</sub>-inch (38 mm) round or 2-inch-by-2-inch (51 mm by 51 mm) square galvanized steel speed clips, and washers and wing nuts for 1/4-inch-diameter (6.4 mm) rod. Access door labels complying with IMC Section 506.3.11 or IAPMO UMC Section 510.1.6, as applicable, must be applied to all access doors. See Figure 2 for details of protection for field-fabricated access doors.

**4.2.2.3 Prefabricated Access Doors:** Ductmate Ultimate and F2-HT prefabricated access doors must be installed in accordance with Ductmate Industries, Inc., installation instructions and the applicable code. The first layer of blanket is cut to the size of the door and each successive layer has an overlap of 1 inch (25.4 mm) over the lower layer. All edges of insulation blanket must be protected with aluminum tape. A No. 16 [0.055 inch (1.4 mm)] gage outer plate the same dimension as the outer layer of insulation blanket is held in place over the insulation using threaded rod and wing nuts provided with the doors. See Figure 2 for assembly details.

**4.2.3 Duct Support:** Horizontal duct assemblies with maximum dimensions of 49 inches by 49 inches (1244.6 mm by 1244.6 mm) are supported with minimum  $\frac{3}{8}$ -inch diameter (9.5 mm) all-thread steel rod and  $1\frac{1}{2}$  inch-by- $1\frac{1}{2}$ -inch-by- $\frac{1}{8}$ -inch (38 mm by 38 mm by 3.2 mm) steel angle, spaced a maximum of 60 inches (1524 mm) on center along the length of the duct. See Figure 3.

For support spacing up to 72 inches on center, horizontal duct assemblies with maximum dimensions of 49 inches by 49 inches (1244.6 mm by 1244.6 mm) must be supported with minimum  $\frac{1}{2}$ -inch-diameter (12.7 mm), all-thread steel rods and 2-inch-by-2-inch-by- $\frac{1}{4}$ -inch (51 mm by 51 mm by 6.4 mm) steel angles. A minimum clearance of 1 inch (25.4 mm) is required between the edge of the protected duct and the steel rod. See Figure 3.

Vertical duct assemblies with maximum dimensions of 49 inches by 49 inches (1244.6 mm by 1244.6 mm) are supported with minimum  $1\frac{1}{2}$ -inch-by- $1\frac{1}{2}$ -inch-by- $\frac{1}{4}$ -inch (38 mm by 38 mm by 6.4 mm) steel angle brackets, located on opposite sides of the duct on the top and bottom of each floor-ceiling assembly. The supports are attached to the duct with welds. Maximum spacing between vertical supports must be established by structural calculations in accordance with the applicable code, that are submitted to the code official for approval.

### 4.3 Through-penetrations:

**4.3.1 General:** Where the system penetrates fire-resistance-rated assemblies, the through-penetration must be protected with an approved through-penetration firestop system. Section 4.3.2 describes two-hour F-rated through-penetration firestop assemblies for walls, and Section 4.3.3 describes two-hour F- and T-rated firestop assemblies for floors/ceilings. Where the grease duct enclosure system penetrates other than the concrete, concrete masonry or gypsum board assemblies described in those sections, the through-penetration must be protected with a through-penetration firestop assembly complying with the applicable code provisions, and use of the firestop assembly must be approved by the code official.

### 4.3.2 Wall Assemblies: Two-hour F-Rated Through-penetration Firestop Assemblies:

**4.3.2.1 Assembly 1:** Where the grease duct protected with the FyreWrap Elite 1.5 or MAX 2.0 enclosure assembly penetrates a fire-resistance-rated concrete or concrete masonry wall assembly or a gypsum board assembly complying with IBC Table 720.1(2), and the penetration requires protection, the annular space of the penetration must be protected as illustrated in Figure 4 and as described below:

- Penetration opening: The maximum area of the opening in the fire-resistance-rated wall assembly is 3105 square inches (2.05 m<sup>2</sup>) with any one dimension a maximum of 57.5 inches (1460 mm).

- Duct wrap material: The grease duct must be wrapped with the blanket material as described in Section 4.2.1.
- Packing material: The annular space is filled completely with unfaced duct wrap material, or minimum 4 pcf (64 kg/m<sup>3</sup>), 4-inch-thick (102 mm) mineral wool, compressed 25 percent and recessed  $\frac{3}{8}$  inch (9.5 mm) from both surfaces of the wall, as required to accommodate the necessary depth of the sealant material.
- Sealant material: The recessed voids created by the packing material must be filled to a minimum depth of  $\frac{3}{8}$  inch (9.5 mm) with Tremco Fyre-Sil sealant described in Section 3.5. The sealant material must overlap onto the wall surface and the duct insulation a minimum of  $\frac{1}{2}$  inch (12.7 mm).

**4.3.2.2 Assembly 2:** Where the grease duct protected with the FyreWrap Elite 1.5 or MAX 2.0 enclosure assembly penetrates a fire-resistance-rated gypsum board wall assembly complying with IBC Table 720.1(2), and the penetration requires protection, the annular space of the penetration must be protected as described in Figure 4 and described below:

- Penetration opening: The maximum area of the opening in the fire-resistance-rated wall assembly is 3393 square inches (2.17 m<sup>2</sup>) with any one dimension a maximum of  $58\frac{1}{4}$  inches (1479 mm).
- Duct wrap material: The grease duct must be wrapped with the blanket material as described in Section 4.2.1.
- Packing material: The annular space is filled completely with unfaced duct wrap material, compressed 48 percent and recessed  $\frac{5}{8}$  inch (15.9 mm) from both surfaces of the wall, as required to accommodate the necessary depth of the sealant material.
- Sealant material: The recessed voids created by the packing material must be filled to a minimum depth of  $\frac{5}{8}$  inch (15.9 mm) with STI SpecSeal SSS intumescent sealant described in Section 3.5. The sealant material must overlap onto the gypsum wallboard and the duct insulation a minimum of  $\frac{1}{2}$  inch (12.7 mm).

### 4.3.3 Floor/Ceiling Assemblies: Two-hour F- and T-rated Through-penetration Firestop Assemblies:

**4.3.3.1 Assembly 3:** Where the grease duct protected with the FyreWrap Elite 1.5 or MAX 2.0 enclosure assembly described in Section 4.2.1 penetrates a minimum  $4\frac{1}{2}$ -inch-thick (114 mm) fire-resistance-rated concrete floor/ceiling assembly complying with IBC Table 720.1(3), the annular space of the penetration must be protected as illustrated in Figure 5 and as described below:

- Penetration opening: The maximum area of the opening in the fire-resistance-rated floor assembly is 3024 square inches (1.95 m<sup>2</sup>) with a maximum opening dimension of 56 inches (1422.4 mm).
- Duct wrap material: The grease duct must be wrapped with the blanket material as described in Section 4.2.1. As an additional installation option, the wrap is permitted to be terminated on each side of the floor/ceiling assembly.
- Packing material: The annular space is filled completely with unfaced duct wrap material, compressed 33 percent and recessed  $\frac{1}{4}$  inch (6.4 mm) from top surface of the floor, as required to accommodate the necessary depth of the sealant material.

- d. Sealant material: The recessed void created by the packing material must be filled to a minimum depth of  $\frac{1}{4}$  inch (6.4 mm) with STI SpecSeal SSS intumescent sealant described in Section 3.5.

**4.3.3.2 Assembly 4:** Where the grease duct protected with the FyreWrap Elite 1.5 or MAX 2.0 enclosure assembly described in Section 4.2.1 penetrates a minimum  $4\frac{1}{2}$ -inch-thick (114 mm) fire-resistance-rated concrete floor/ceiling assembly complying with IBC Table 720.1(3), the annular space of the penetration must be protected as illustrated in Figure 6 and as described below:

- a. Penetration opening: The maximum area of the opening in the fire-resistance-rated floor assembly is 3105 square inches (2.05 m<sup>2</sup>) with a maximum opening dimension of 57.5 inches (1460 mm).
- b. Duct wrap material: The grease duct must be wrapped with the blanket material as described in Section 4.2.1.
- c. Packing material: The annular space is filled completely with unfaced duct wrap material, or minimum 4 pcf (64 kg/m<sup>3</sup>), 4-inch-thick (102 mm) mineral wool, compressed 25 percent and recessed  $\frac{3}{8}$  inch (9.5 mm) from top surface of the floor, as required to accommodate the necessary depth of the sealant material.
- d. Sealant material: The recessed void created by the packing material must be filled to a minimum depth of  $\frac{3}{8}$  inch (9.5 mm) with Tremco Fyre-Sil sealant described in Section 3.5. The sealant material must overlap onto the concrete and the duct insulation a minimum of  $\frac{1}{2}$  inch (12.7 mm).

**4.3.3.3 Assembly 5:** Where the grease duct protected with the FyreWrap Elite 1.5 or MAX 2.0 enclosure assembly described in Section 4.2.1 penetrates a minimum  $4\frac{1}{2}$ -inch-thick (114 mm) fire-resistive concrete floor/ceiling assembly complying with IBC Table 720.1(3), the annular space of the penetration must be protected as illustrated in Figure 6 and as described below:

- a. Penetration opening: The maximum area of the opening in the fire-resistance-rated floor assembly is 1792 square inches (1.16 m<sup>2</sup>) with a maximum opening dimension of 56 inches (1422.4 mm).
- b. Duct wrap material: The grease duct must be wrapped with the blanket material as described in Section 4.2.1.
- c. Packing material: The annular space is filled completely with nominally 4 pcf (64 kg/m<sup>3</sup>) mineral wool, cut into strips approximately  $\frac{1}{2}$  inch (12.7 mm) thick, rolled tightly and inserted lengthwise into the annular space. The mineral wool is recessed  $\frac{1}{4}$  inch (6.4 mm) from top surface of the floor, as required to accommodate the necessary depth of the sealant material.
- d. Sealant material: The recessed void created by the packing material must be filled to a minimum depth of  $\frac{1}{4}$  inch (6.4 mm) with GE Silicone Pensil 300 sealant described in Section 3.5.

**4.3.3.4 Assembly 6:** Where the grease duct protected with the FyreWrap Elite 1.5 or MAX 2.0 enclosure assembly described in Section 4.2.1 penetrates a minimum  $4\frac{1}{2}$ -inch-thick (114 mm) fire-resistance-rated concrete floor/ceiling assembly complying with IBC Table 720.1(3), the annular space of the penetration must be protected as illustrated in Figure 7 and as described below:

- a. Penetration opening: The maximum area of the opening in the fire-resistance-rated floor assembly is 3481 square inches (2.25 m<sup>2</sup>) with a maximum opening dimension of 59 inches (1498.6 mm).
- b. Duct wrap material: The grease duct must be wrapped with the blanket material as described in Section 4.2.1. As an additional installation option, the wrap is permitted to be terminated on each side of the floor/ceiling assembly.
- c. Packing material: The annular space is filled completely with unfaced duct wrap material, compressed 33 percent and recessed  $\frac{3}{8}$  inch (9.5 mm) from the top surface of the floor, as required to accommodate the necessary depth of the sealant material.
- d. Sealant material: The recessed void created by the packing material must be filled to a minimum depth of  $\frac{3}{8}$  inch (9.5 mm) with 3M FireBarrier 1000NS, Hilti FS-ONE, STI SpecSeal SSS or Tremco Fyre-Sil, as described in Section 3.5.

## 5.0 CONDITIONS OF USE

The FyreWrap Elite 1.5 or MAX 2.0 grease duct enclosure assemblies described in this report comply with, or are suitable alternatives to what is specified in, those codes listed in Section 1.0 of this report, subject to the following conditions:

- 5.1** The enclosure system must be constructed and installed in accordance with this report. In the event of a conflict between this report and the manufacturer's instructions, this report governs.
- 5.2** The blanket materials are manufactured in New Carlisle, Indiana, under a quality control program with inspections by Intertek Testing Services NA Inc. (AA-690).

## 6.0 EVIDENCE SUBMITTED

- 6.1** Data in accordance with the ICC-ES Acceptance Criteria for Grease Duct Enclosure Assemblies (AC101), dated April 2001 (editorially revised October 2004).
- 6.2** Data in accordance with ASTM E 2336.
- 6.3** Quality documentation.

## 7.0 IDENTIFICATION

The FyreWrap Elite 1.5 and MAX 2.0 blanket materials are packaged in boxes bearing the product name, the company name (Unifrax I LLC) and address, the surface-burning characteristics, the name of the inspection agency (Intertek Testing Services NA Ltd.), and the evaluation report number (ESR-2224). The wording "FyreWrap" and "Fire-resistive Enclosure, Do Not Remove" and the evaluation report number (ESR-2224) are printed on blankets at approximate 4-foot (1219 mm) intervals. Sealants used for through-penetration firestops are labeled with the manufacturer's name and the product name. Prefabricated access doors are labeled with the DuctMate Industries, Inc., name, the product name and the model number.

## 8.0 Other Codes

The products described in this report have also been evaluated for compliance with the following codes:

- 2006 *International Building Code*® (2006 IBC)
- 2006 *International Mechanical Code*® (2006 IMC)

- 2006 IAMPO *Uniform Mechanical Code*<sup>®</sup> (2006 IAMPO UMC)
- 2003 *International Building Code*<sup>®</sup> (2003 IBC)
- 2003 *International Mechanical Code*<sup>®</sup> (2003 IMC)
- 2003 IAPMO *Uniform Mechanical Code*<sup>®</sup> (2003 IAPMO UMC)
- 1997 *Uniform Building Code*<sup>™</sup> (UBC)

Compliance with these codes is as described in Sections 2.0 through 7.0 of this report, except the applicable code sections or tables are as follows:

- Section 2.0:
  - 2006 and 2003 IBC Section 707.4
  - 2006 and 2003 IAPMO UMC Section 510.7.1
  - UBC Section 711
- Section 3.2:
  - Joints and seams of grease ducts:
    - 2006 and 2003 IMC Section 506.5.2
    - 2006 and 2003 IAPMO UMC Section 510.3.2
  - Duct supports:
    - 2006 and 2003 IMC Section 506.3.3
    - 2006 and 2003 IAPMO UMC Section 510.1.7
- Section 4.1:
  - 2006 and 2003 IMC Section 602.2.1
  - 2006 and 2003 IAPMO Section 602.2
- Section 4.2.2.1:
  - 2006 IMC Section 506.3.8
  - 2003 IMC Sections 506.3.9 and 506.3.11
  - 2006 and 2003 IAPMO UMC Section 510.3
- Section 4.3.2.1
  - 2006 and 2003 IBC Table 720.1(2)
  - UBC Table 7-B
- Section 4.3.2.2
  - 2006 and 2003 IBC Table 720.1(2)
  - UBC Table 7-B
- Section 4.3.3.1
  - 2006 and 2003 IBC Table 720.1(3)
  - UBC Table 7-C
- Section 4.3.3.2
  - 2006 and 2003 IBC Table 720.1(3)
  - UBC Table 7-C
- Section 4.3.3.3
  - 2006 and 2003 IBC Table 720.1(3)
  - UBC Table 7-C
- Section 4.3.3.4
  - 2006 and 2003 IBC Table 720.1(3)
  - 1997 UBC Table 7-C

FyreWrap® Elite™1.5 or FyreWrap® MAX 2.0 Duct Insulation  
 Installation Methods  
 1 or 2 Hour Fire Rated Enclosure, Shaft Alternative  
 Zero Clearance To Combustibles

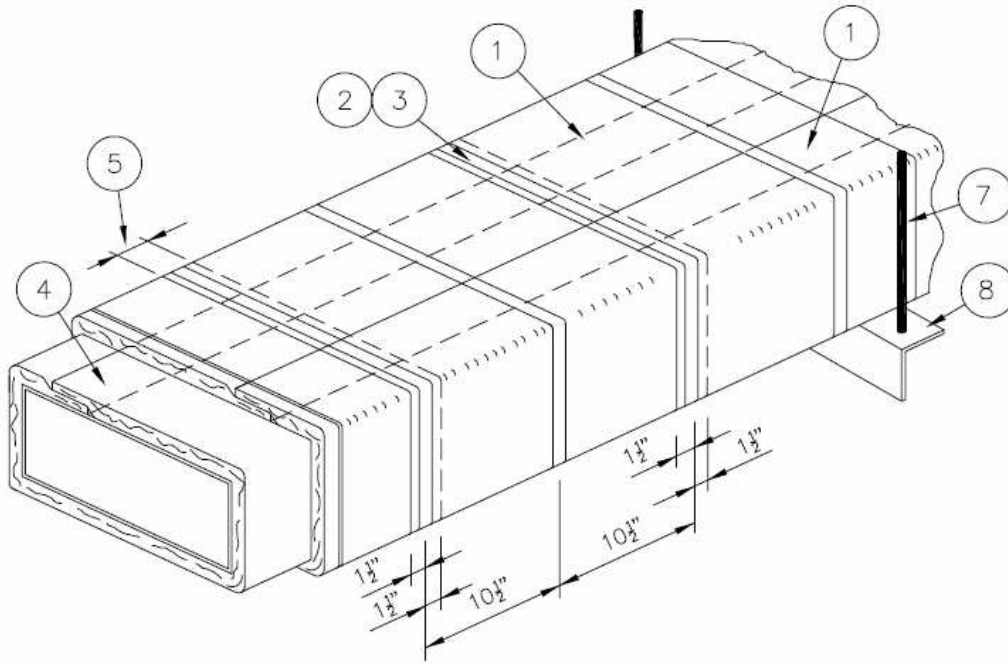

INSTALLATION METHODS:

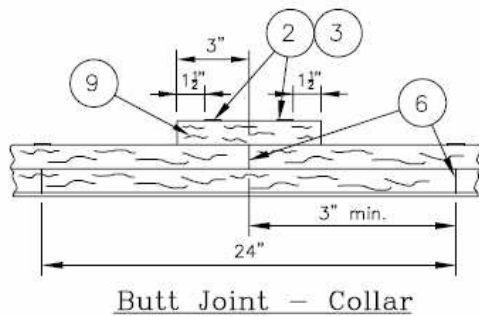
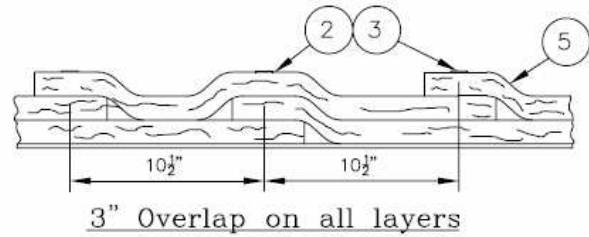
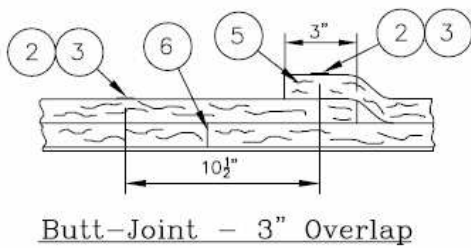

Legend:	
1	FyreWrap® Elite™1.5 or FyreWrap MAX®2.0 Duct Insulation, Two Layers
2	Filament Tape (Temporary Hold)
3	Banding Straps (Permanent Hold)
4	3" Minimum Longitudinal Overlap
5	3" Minimum Transverse Overlap
6	1" Compressed Butt Joint
7	Steel Hanger Rod
8	Steel Angle
9	6" wide FyreWrap® Elite™1.5 or FyreWrap® MAX 2.0 Collar

**FIGURE 1**

FyreWrap® Elite™1.5 or FyreWrap®MAX 2.0 Duct Insulation  
Access Door Systems

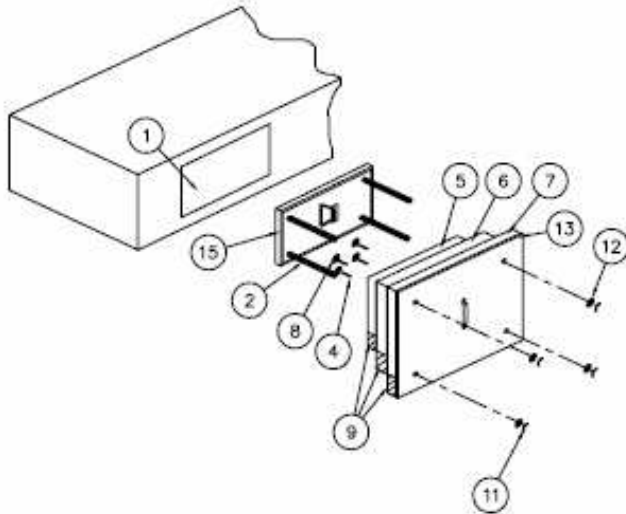

Ductmate Ultimate Door System

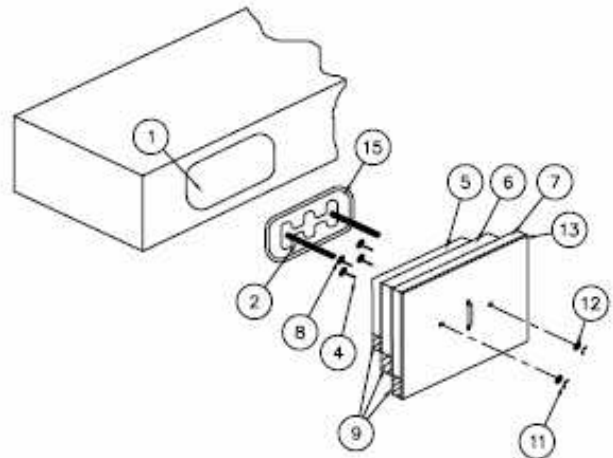

Ductmate F2-HT Door System

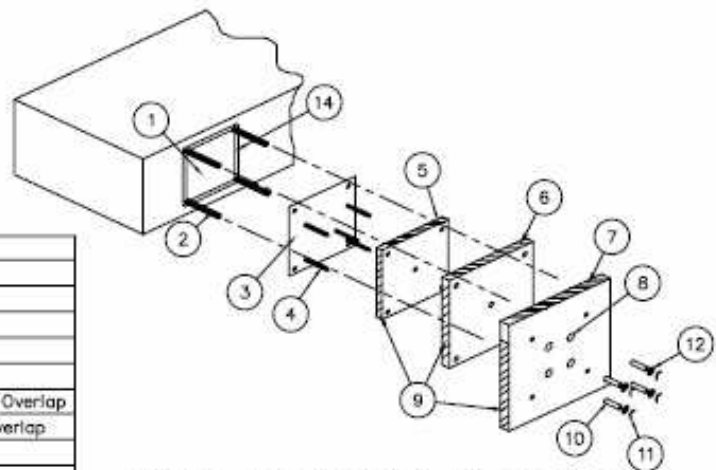

Field Fabricated Door System

Legend:	
1	Access Door Opening
2	All Thread Rods
3	Access Door Cover Panel 16 Gauge (field fab. only)
4	Insulation Pins – Welded to Cover
5	First Layer FyreWrap® Elite™1.5 or FyreWrap®MAX 2.0,
6	Second Layer FyreWrap® Elite™1.5 or FyreWrap®MAX 2.0, 1" Overlap
7	Third Layer FyreWrap® Elite™1.5 or FyreWrap®MAX 2.0, 1" Overlap
8	Speed Clips/Washers
9	Cut Edges Sealed With Aluminum Foil Tape
10	Spool pieces for threaded rods(optional field fab. only)
11	Wing Nuts
12	Washers
13	Insulation plate
14	Ceramic fiber or Unfaced FyreWrap® gasket, ½" thick
15	Pre-fabricated access door

FIGURE 2

## FyreWrap® Elite™ 1.5 or FyreWrap® MAX 2.0 Duct Insulation Typical Duct Support Details

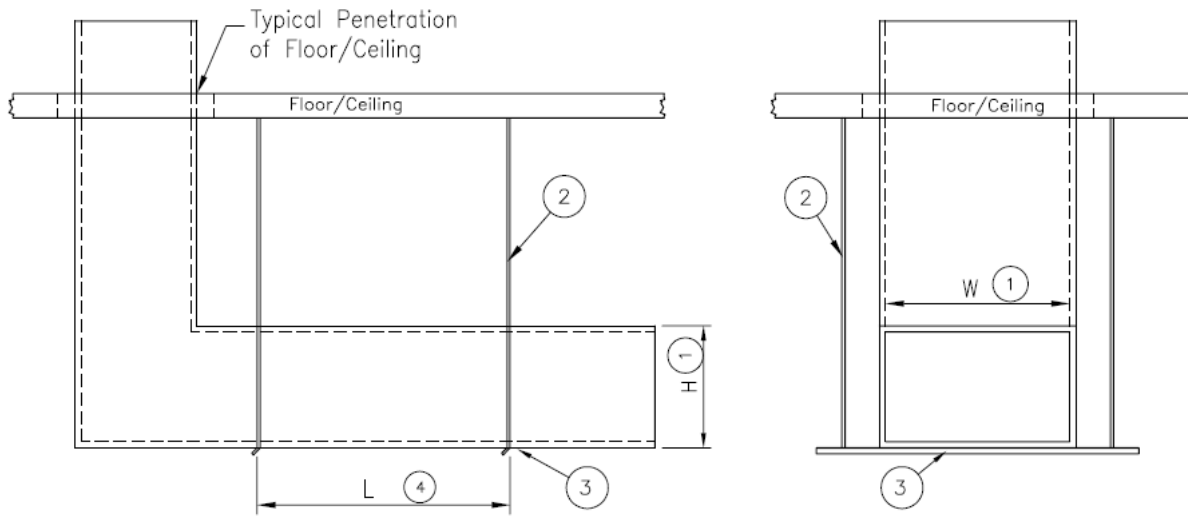

### Typical Horizontal Duct Support Details

Legend:			
1	Max. Duct Size (HxW)	49"x49"	49"x49"
2	Steel Threaded Rod	$\frac{3}{8}$ " diameter	$\frac{1}{2}$ " diameter
3	Steel Angle	$1\frac{1}{2}$ "x $1\frac{1}{2}$ "x $\frac{1}{8}$ "	2"x2"x $\frac{1}{2}$ "
4	Support System Spacing (L)	60"	72"

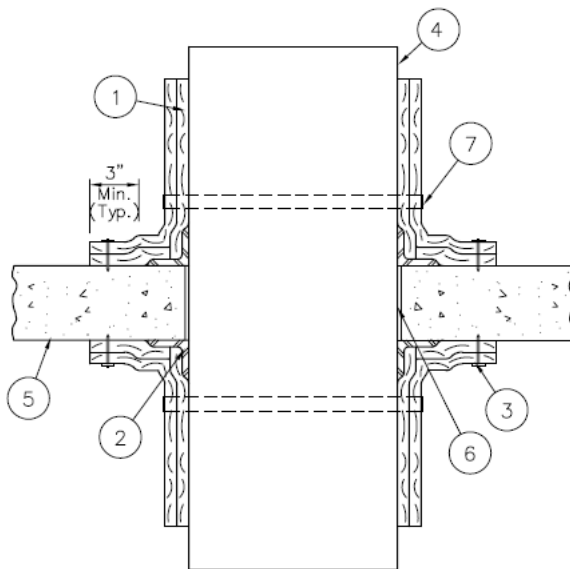

Legend:	
1	FyreWrap® Elite™ 1.5 or FyreWrap® MAX 2.0 Duct Insulation, Two Layers
2	Duct Support Mechanism
3	Mechanical Fasteners & Washers
4	Grease Duct
5	Fire Resistive Concrete Floor/Ceiling Assembly
6	Firestop System
7	Steel Banding and Clips

### Typical Vertical Duct Support Details

**FIGURE 3**

**FyreWrap® Elite™1.5 or FyreWrap® MAX 2.0 Duct Insulation  
Through Penetration Wall Systems,  
F Rating = 2 hrs. T Rating = 2 hrs.**

---

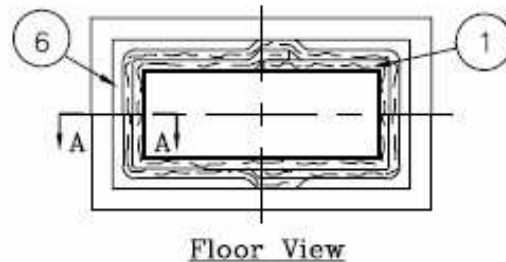
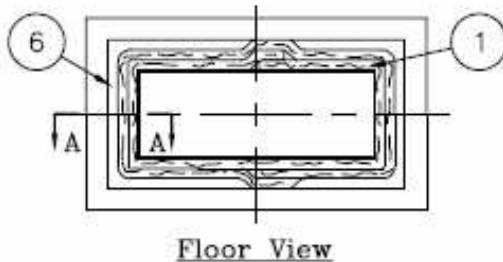
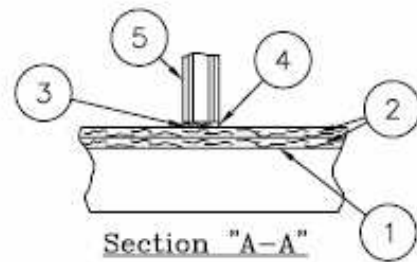
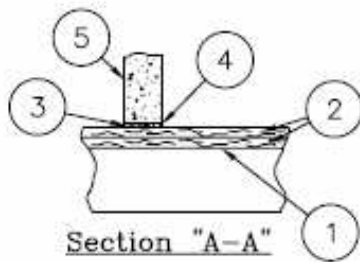

Legend:	
1	Grease Duct, max. 240in <sup>2</sup> area, 49" max width
2	FyreWrap® Elite™1.5 or FyreWrap® MAX 2.0 Duct Insulation, Two Layers
3	Unfaced FyreWrap® Elite™1.5 or FyreWrap® MAX 2.0 or
4	4 pcf Mineral Wool (4½", compressed 25%)
5	Tremco Fyre-Sil, ½" depth, and overlapped onto wall surface and duct insulation ½"
6	Fire-Resistive Concrete or Concrete block wall Ass'y.

Legend:	
1	Grease Duct, max. 240in <sup>2</sup> area, 49" max width
2	FyreWrap® Elite™1.5 or FyreWrap® MAX 2.0 Duct Insulation, Two Layers
3	Unfaced FyreWrap® Elite™1.5 or FyreWrap® MAX 2.0 or
4	4 pcf Mineral Wool (4½", compressed 25%)
5	Tremco Fyre-Sil, ½" depth, and overlapped onto wall surface and duct insulation ½"
6	Fire-Resistive Gypsum Wall Ass'y.

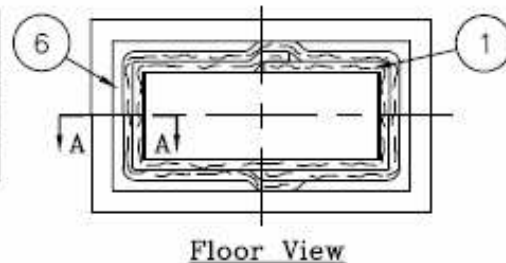
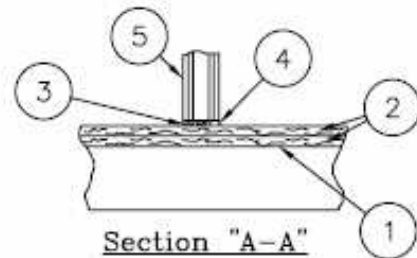

Legend:	
1	Grease Duct, max. 240in <sup>2</sup> area, 49" max width
2	FyreWrap® Elite™1.5 or FyreWrap® MAX 2.0 Duct Insulation, Two Layers
3	Unfaced FyreWrap® Elite™1.5 or FyreWrap® MAX 2.0 (3½", compressed 48%)
4	STI Spec Seal SSS, ½" depth
5	Fire-Resistive Gypsum Wall Assembly
6	Annular space 0" to 3½"

FIGURE 4

**FyreWrap® Elite™1.5 or FyreWrap® MAX 2.0 Duct Insulation  
Through Penetration Floor/Ceiling Systems,  
F Rating = 2 hrs. T Rating = 2 hrs.**

---

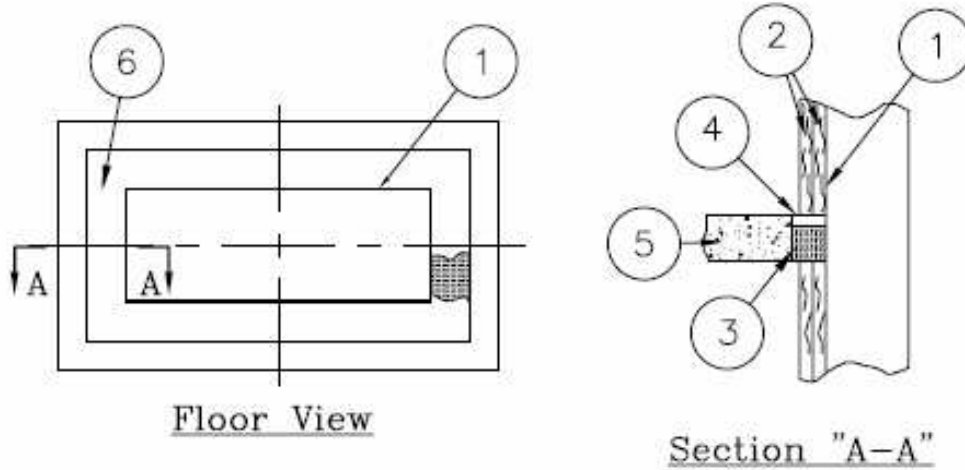

Duct Wrap Insulation Terminated at Floor

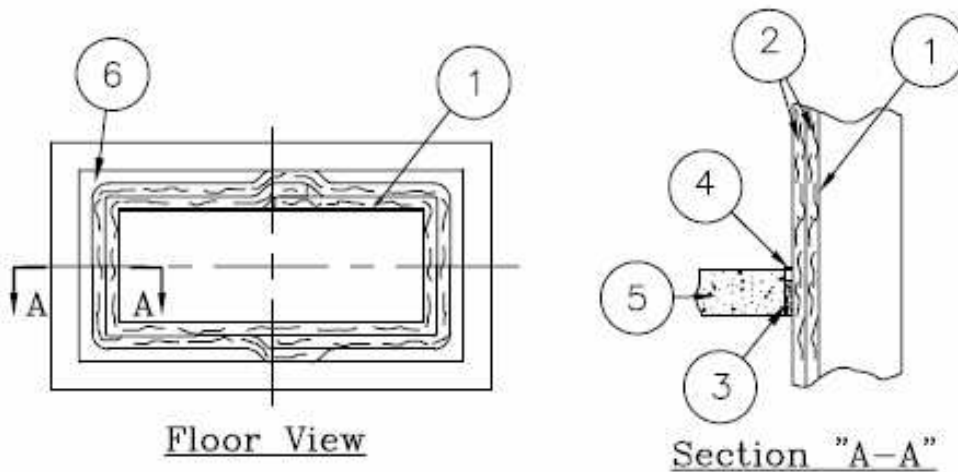

Duct Wrap Insulation continues Through Floor

Legend:	
1	Grease Duct, max. 2401in <sup>2</sup> area, 49" max width
2	FyreWrap® Elite™1.5 or FyreWrap® MAX 2.0 Duct Insulation, Two Layers
3	Unfaced FyreWrap® Elite™1.5 or FyreWrap® MAX 2.0 (4½", compressed 33%)
4	STI Spec Seal SSS, ¼" depth
5	Fire-Resistive Concrete Floor/Ceiling Assembly
6	Annular space, 1" to 2"

FIGURE 5

**FyreWrap® Elite™1.5 or FyreWrap® MAX 2.0 Duct Insulation  
Through Penetration Floor/Ceiling Systems,  
F Rating = 2 hrs. T Rating = 2 hrs.**

---

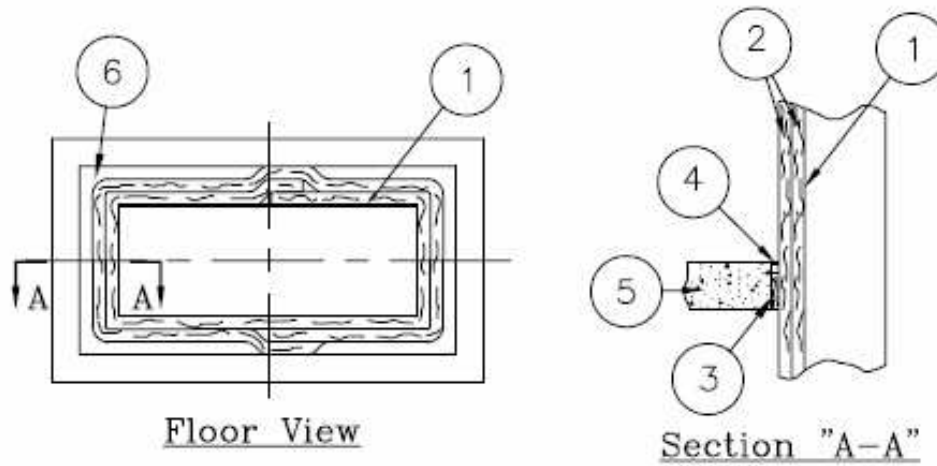

Legend:	
1	Grease Duct, max. 240in <sup>2</sup> area, 49" max width
2	FyreWrap® Elite™1.5 or FyreWrap® MAX 2.0 Duct Insulation, Two Layers
3	Unfaced FyreWrap® Elite™1.5 or FyreWrap® MAX 2.0 or 4 pcf Mineral Wool (4", compressed 25%)
4	Tremco Fyre-Sil, 3/8" depth, and overlapped onto concrete and duct insulation 1/2"
5	Fire-Resistive Concrete Floor/Ceiling Ass'y.
6	Annular space 1" to 5"

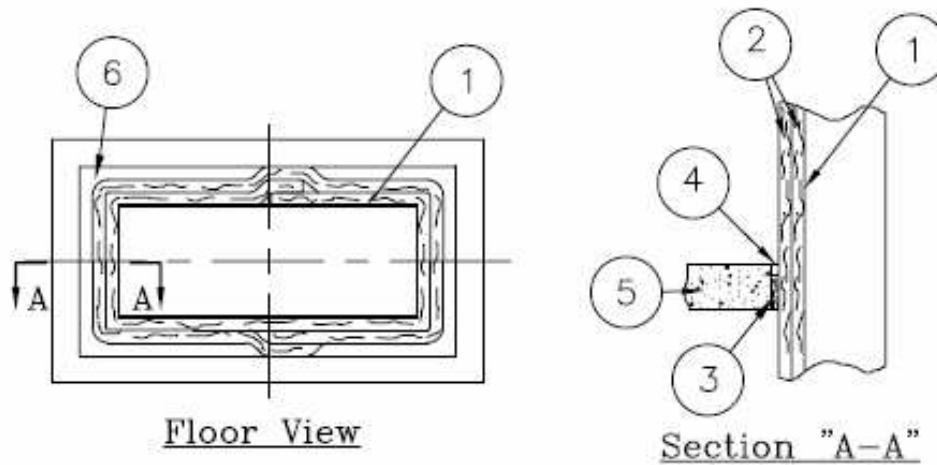

Legend:	
1	Grease Duct, max. 1152 in <sup>2</sup> area, 48" max width
2	FyreWrap® Elite™1.5 or FyreWrap® MAX 2.0 Duct Insulation, Two Layers
3	Mineral Wool, 4 pcf, tightly packed
4	STI Pensil 300, 1/2" depth
5	Fire-Resistive Concrete Floor/Ceiling Ass'y.
6	Annular space, maximum 1"

FIGURE 6

FyreWrap® Elite™ 1.5 or FyreWrap® MAX 2.0 Duct Insulation  
Through Penetration Floor/Ceiling Systems,  
F Rating = 2 hrs. T Rating = 2 hrs.

---

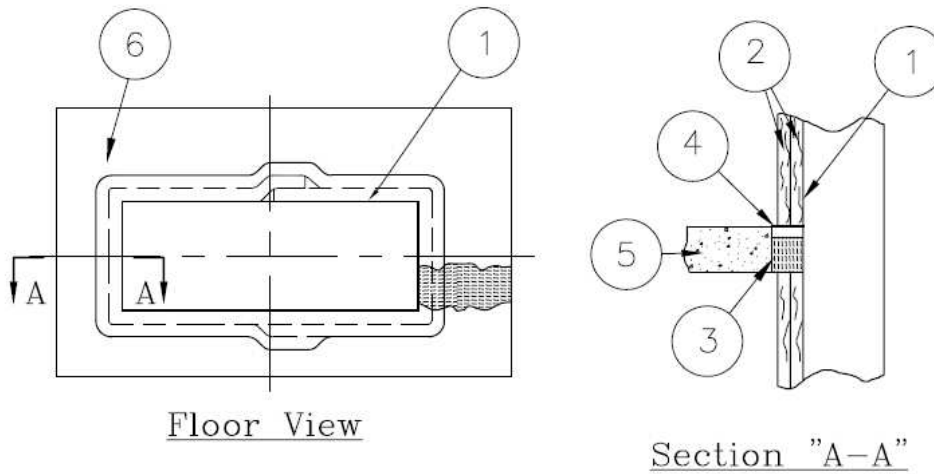

Duct Wrap Insulation Terminated at Floor

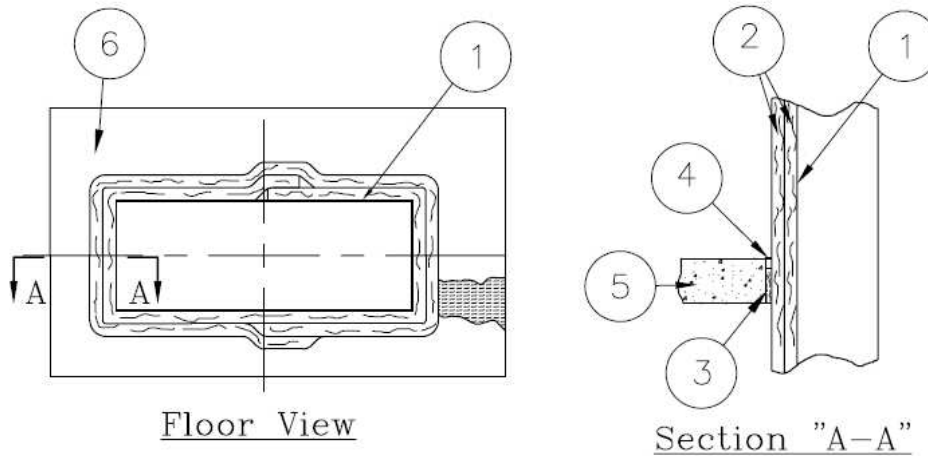

Duct Wrap Insulation continues Through Floor

Legend:	
1	Grease Duct, max. 240in <sup>2</sup> area, 49" max width
2	FyreWrap® Elite™ 1.5 or FyreWrap® MAX 2.0 Duct Insulation, Two Layers
3	Unfaced FyreWrap® Elite™ 1.5 or FyreWrap® MAX 2.0 (4", compressed 33%)
4	Firestop Sealant, 3/8" depth, 3M Fire Barrier 1000NS or Hilti FS-ONE or STI SpecSeal SSS or Tremco FyreSil
5	Fire-Resistive Concrete Floor/Ceiling Assembly
6	Annular space, 1" to 3"

**FIGURE 7**