

D U C T M A T E

Ovalmate™



OVAL
CONNECTION SYSTEMS



4-Bolt Flat Oval Duct Connection System



Virtually Airtight Connection for Flat Oval Duct Sections

- Airtight, efficient
- Simple and easy connection
- Consistent connections
- Can be installed on-site
- No additional sealing required
- Will accommodate flat oval duct sizes 10" - 36" in height
- Available in specialty metals



DUCTMATE®

Industries, Inc.

Ovalmate™

4-Bolt Flat Oval Duct Connection System

DESCRIPTION

4-bolt flat oval duct connection system

BASIC USE

The Ovalmate flat oval duct connection system was developed to provide an easier, virtually air-tight, connection for flat oval duct sections at a lower overall cost and with excellent appearance.

SPECIAL CHARACTERISTICS

The Ovalmate System has been tested by Professional Service Industries. Test results reveal virtually no leakage at up to 18" WG positive pressure or down to 10" WG negative pressure.

The Ovalmate flat oval duct connection is not recommended for applications with duct gauges heavier than 16 GA with spiral lock seam or lighter than 28 GA.

Width of pocket is sufficient to accommodate spiral lock

Flange Steel:	hot dipped galvanized steel
Connector Pieces:	hot dipped galvanized steel
Cleats:	hot dipped galvanized steel
Mastic:	Ductmate DM 5511M
Gasket:	Ductmate 440 and Ductmate Neoprene gasket.

PRODUCT GUARANTEE

All component parts of the Ovalmate System are guaranteed against defective material.

PACKAGING INFORMATION

- Semi-circular End Flange sections with integral mastic in the duct receiving pocket.
- Straight Flange sections (1 for each flat side) with integral mastic in the duct receiving pocket. Shipped in 20 ft. lengths.
- Connector Pieces (Connector pieces are shipped already inserted in the end flange sections. Four connector pieces per completed frame)
- Screw-type Cleats

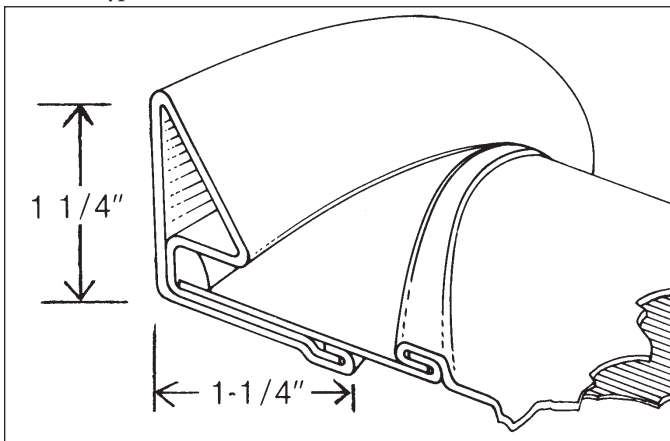

INSTALLATION INSTRUCTIONS

CUTTING OVALMATE ANGLE

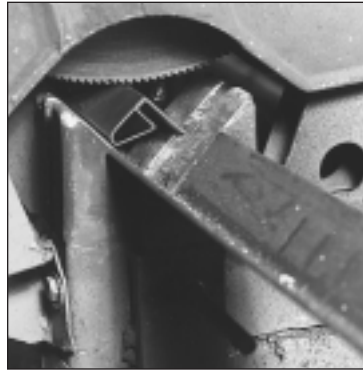

- Slam the blade through the Angle as quickly as possible. Saw must have sufficient horsepower. Always use a metal friction saw blade. A band saw or hack saw can also be used.

NOTE: Cut straight Ovalmate angle to length according to the following formulas:

FORMULA 1

For Duct With 10" through 36" Minor Dimension

EXAMPLE	
Duct Dimension 68" x 20"	
Major Dimension	68"
(minus) Minor Dimension	-20"
(minus) 6 1/4"	-6 1/4"
(equals) Straight Ovalmate Angle Length	41 3/4"

FORMULA 2

For Duct With 38" and Larger Minor Dimension

EXAMPLE	
Duct Dimension 68" x 38"	
Major Dimension	68"
(minus) Minor Dimension	-38"
(minus) 2 1/4"	-2 1/4"
(equals) Straight Ovalmate Angle Length	27 3/4"

* Formula is based on exact dimensions. Measure your frame and check fit of completed frame

- Ovalmate not recommended when formula calculates angle length at less than 4".



- Never cut Ovalmate angle with legs up as metal chips may fall into the mastic.

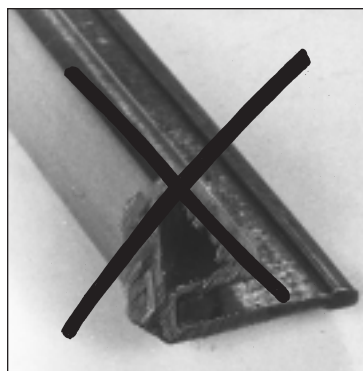

- Never use an abrasive blade to cut Ovalmate angle as the heat can melt out the integral mastic and cause excessive burning.

ASSEMBLING OVALMATE FRAME

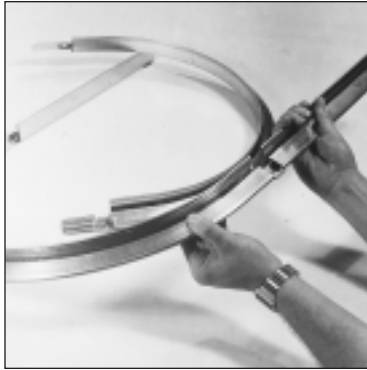

4. Slide the two "straight" oval angle pieces onto the connector pieces already inserted into the curved Ovalmate sections.



5. Complete the Ovalmate frame by connecting both "straight" flange sections and curved Ovalmate sections into a finished frame ready to attach to the raw duct end.

SEATING OVALMATE FRAME

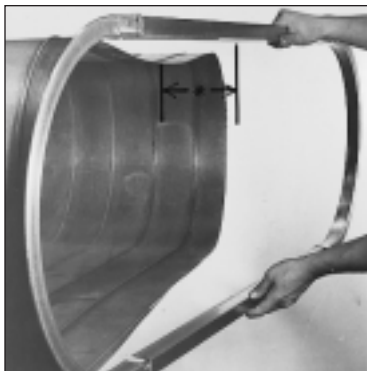

6. Begin seating Ovalmate.

NOTE: Mark a common reference point on both ends of the duct. Ovalmate frames must be centered properly in relation to the frame on the other side of the duct to eliminate racking and/or twisting.



7. If the raw edge of the duct gets caught behind the Ovalmate connector piece, press the duct with your fingers while tapping the frame in order to assure that the duct will be correctly seated into the integral mastic.



8. Use a mallet to seat the Ovalmate frame onto the duct. Do not hammer the center of the major axis. An inward curve could occur. Make sure cut edge of the duct is square. Metal to metal contact is preferred between duct and frame but you may have to adjust in order to square the connection.

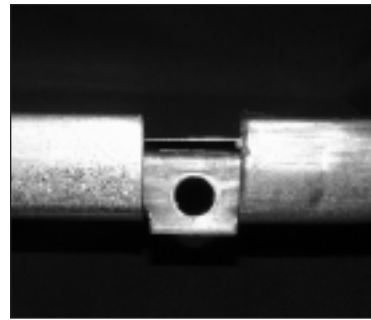

9. The duct must be seated all the way into the Ovalmate angle in order to penetrate the integral sealant and avoid air leaks. Double check to make sure that the duct edge protrudes past the downset of each Ovalmate connector piece.

FASTENING OVALMATE FRAME TO DUCT

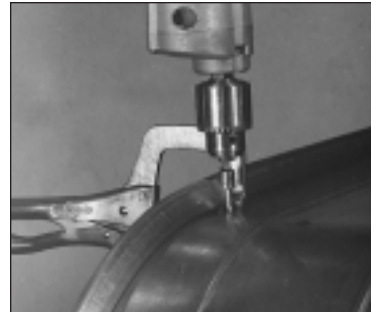

10. Work in one direction around duct when seating the frame. Fasten in sequence as you go.

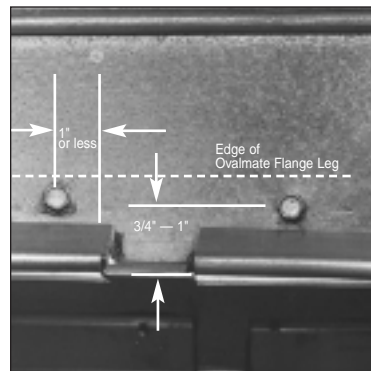

11. Begin securing the leg of the Ovalmate flange to the duct section by clamping seated frame close to one of the Ovalmate connector pieces. Place a pop rivet, screw or spot weld within 1" of the flange end and no closer than 3/4" or further away than 1" from the face of the flange.

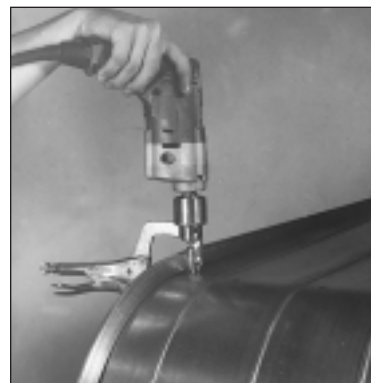

12. Continue in one direction around the duct at evenly spaced intervals as per the schedule below. Place last fastener within 1" of the end of a straight or curved flange section.

SCHEDULE:

Duct height: 12" to 18"

Fasten 8" on centers

Duct height: 20" to 36"

Fasten 12" on centers

Frequently a contractor installing a high velocity duct system will employ a duct joint with which either he or his work force have no experience. In such a case, it is strongly recommended that the contractor promptly test the initial 100 to 300 feet of duct before installing any more duct. This test will quickly reveal whether or not the workmen can make this joint air-tight in an economical manner.

Reprinted from SMACNA High Pressure Manual.

APPLYING GASKET TAPE

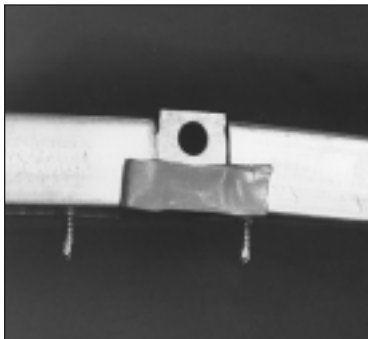

13. On all Ovalmate connector pieces apply Ductmate 440 Gasket as in photo (approx. 3"). Position 440 Gasket so that it covers the raw edge of the duct protruding past the Ovalmate connector pieces.

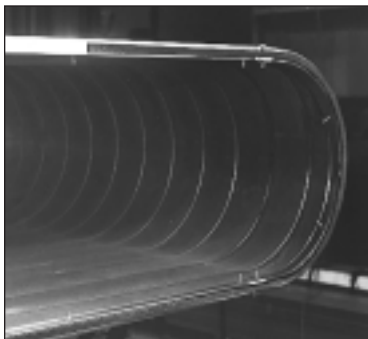

14. Start applying Ductmate Neoprene Gasket Tape to the face of the straight Ovalmate angle about halfway between connector pieces. Position gasket in the center of the Ovalmate angle as in photo. When crossing connector pieces place the gasket over the raw edge of the duct.



15. Press gasket firmly into contact with the face of the Ovalmate flange and the connector pieces. Ductmate Neoprene is the preferred gasket.

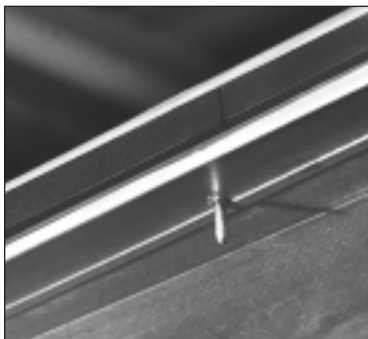

16. Apply Neoprene Gasket completely around Ovalmate frame to the beginning point. Where gasket meets cut so ends butt up against each other.

CONNECTING THE FLAT OVAL DUCT SECTIONS



17. Align mating frames. A drift pin or Ductmate alignment grips can be used to correct any misalignment. Compress gasket with clamps.



18. Insert bolts and tighten nuts.

CLEAT INSTALLATION



19. Clamp the mating Ovalmate angle and clip Ovalmate cleat into position.



20. Now press the cleat into position and fasten with a metal screw. Install at intervals according to the following schedule:

DUCT CURVED SECTIONS:

12" - 18" (1 centered on each curved section)

20" - and larger (2 equally spaced on each curved section)

DUCT STRAIGHT SECTIONS:

18" centers or to provide adequate compression of the gasket. This should only be necessary when the duct is **not** cut straight.

Distributed By:



CHARLEROI, PA
210 Fifth Street
Charleroi, PA 15022
800-245-3188
724-258-0500
FAX: 724-258-5494

LODI, CA
810 S. Cluff Avenue
Lodi, CA 95240-3141
800-344-3270
209-333-4680
FAX: 209-333-4678

www.ductmate.com

Ductmate is a proud member of the following organizations:

