

D U C T M A T E

**ECONO *flange***<sup>TM</sup>



ROUND  
CONNECTION SYSTEMS



## Round Duct Connection System

### Fast Screw Connection

- Simple installation process
- Can be installed on-site
- No special tools required
- Available in sizes 8" - 72" in standard 2" increments
- Available in specialty metals



**DUCTMATE**<sup>®</sup>

**Industries, Inc.**

# ECONOflange

## Round Duct Connection System

### DESCRIPTION

Round duct connection system

### BASIC USE

The ECONOflange connection system was designed as an alternative round duct connection for applications in which appearance and performance are not paramount.

### SPECIAL CHARACTERISTICS

#### Flange Construction:

Hot-dipped galvanized steel, cold-formed.

48" and under:  
18 gauge steel

50" and up:  
16 gauge steel

#### Gasket:

Ductmate Neoprene

### ECONOflange

8" - 72"

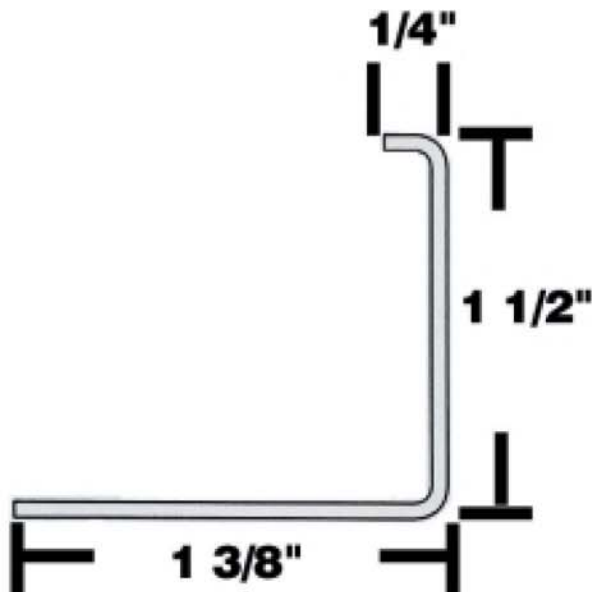

### PRODUCT GUARANTEE

All component parts of ECONOflange system are guaranteed against defective material.

### PACKAGING INFORMATION

The ECONOflange connection system is sold in single rings.

### INSTALLATION INSTRUCTIONS



1. ECONOflange is manufactured with a split in the ring to allow for minor deviations in the diameter of the pipe.



2. Start the ring by inserting the 1 3/4" leg inside the duct.



3. Seat the ring flush with the end of the duct and clamp the ring into position.



4. Begin securing the leg of the ring to the duct section at the split. Hold the flange in position by placing vise grips a few inches from the break. Begin placing a self drilling screw, spot weld, or line rivet 1/2" from the break.



5. Continue in one direction attaching the flange to the duct 1" from the face of the flange, 10" on center around the circumference of the duct. Optional stitch welding around *ECONOflange* to duct 10" center. Assure stitch welds cover 50% onto duct and 50% onto flange for a strong weld.



6. Seal the joint internally with PROseal duct sealant. Brush the sealer into the joint achieving a 100% seal.



7. The break in the flange will allow a portion of the leading edge of the duct to be visible. For a better seal on medium to high pressure jobs (4" and higher) it is preferred that a short piece of Ductmate 440 gasket be applied to the face of the flange to cover the leading edge on both mating flanges. (On low pressure jobs the 440, applied to the split, can be replaced by Ductmate Neoprene gasket.



8. Apply Ductmate Neoprene gasket 5/16" by 3/4" wide to the face of one of the *ECONOflange* Rings. The Neoprene should be positioned parallel to the inside edge of the *ECONOflange*. The Neoprene gasket ends must be butted against each other.



9. Align mating frames by matching the *ECONOflange* ring evenly around the circumference.



10. Clamp the mating *ECONOflange* rings compressing the gasket until the mating rings touch.



11. Fasten self drilling screws 6" on center around the circumference of the flange face. In order to assure a proper closed joint, the rings should be clamped tightly together with the two faces touching each other prior to fastening the self drilling screw. Proper care should be taken in setting the clutch adjustment of your screw gun to assure your screws have 100% holding strength.

*\*\* Econoflange can be installed on reducing fittings in the same manner as a small end collar. This eliminates the need for collars unlike other traditional flange connecting systems.*



**CHARLEROI, PA**  
210 Fifth Street  
Charleroi, PA 15022  
800-245-3188  
724-258-0500  
FAX: 724-258-5494

**LODI, CA**  
810 S. Cluff Avenue  
Lodi, CA 95240-3141  
800-344-3270  
209-333-4680  
FAX: 209-333-4678

[www.ductmate.com](http://www.ductmate.com)

Distributed By:

Ductmate is a proud member  
of the following organizations:

